

TOTAL RATED LOADS

(1) With outriggers set
 [BOOM]

Unit: ton

Outriggers fully extended (4.5m)							-360 °-
A \ B	5.2m	8.8m	12.4m	16.0m	19.6m	23.2m	
1.0m	10.00(4.90)	4.90					
1.5m	10.00(4.90)	4.90	4.90				
2.0m	10.00(4.90)	4.90	4.90	4.00			
2.5m	10.00(4.90)	4.90	4.90	4.00	3.50		
3.0m	8.00(4.90)	4.90	4.90	4.00	3.50	2.00	
3.5m	6.10(4.90)	4.90	4.90	4.00	3.50	2.00	
4.0m	5.40(4.90)	4.90	4.90	4.00	3.50	2.00	
4.5m	(3.9m)	4.60	4.20	4.00	3.50	2.00	
5.0m		4.20	3.80	3.55	3.15	2.00	
5.5m		3.80	3.45	3.15	2.90	2.00	
6.0m		3.35	3.15	2.85	2.70	2.00	
7.0m		2.75	2.65	2.38	2.30	1.80	
8.0m		2.45(7.5m)	2.20	2.00	1.95	1.60	
9.0m			1.75	1.75	1.70	1.45	
10.0m			1.38	1.55	1.50	1.30	
11.0m			1.10	1.30	1.33	1.20	
12.0m				1.08	1.13	1.10	
13.0m				0.90	0.97	1.00	
14.0m				0.75	0.83	0.86	
15.0m				0.65(14.7m)	0.70	0.75	
16.0m					0.60	0.66	
17.0m					0.50	0.57	
18.0m					0.42	0.50	
19.0m					0.40(18.3m)	0.42	
20.0m						0.35	
21.9m						0.26	
a (°)	0 ~ 82						

A= Boom length B= Working radius
 a= Boom angle range (for the unladen condition)

WORKING RADIUS - LIFTING HEIGHT

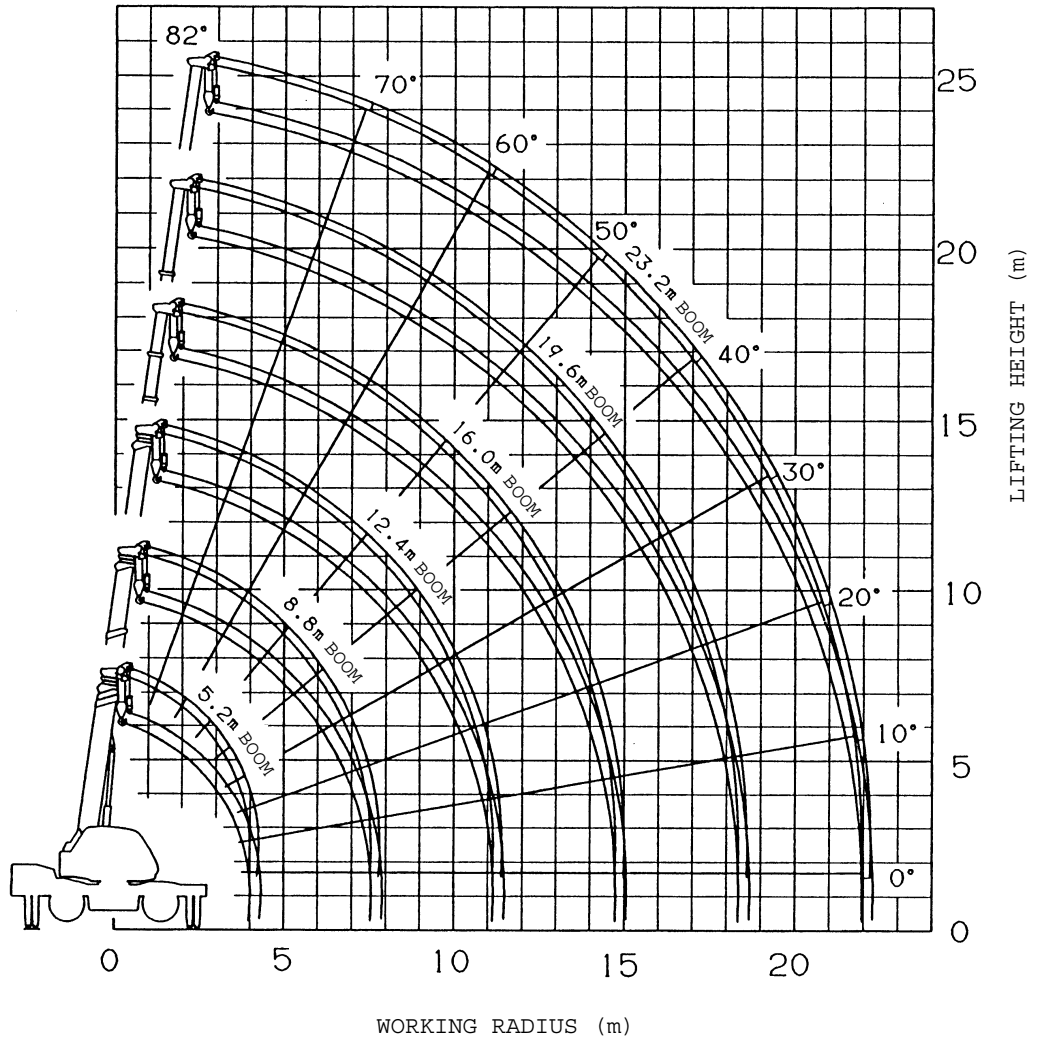

NOTES:

1. The deflection of the boom is not incorporated in the figure above.
2. The figure above is for the case where the outriggers are fully extended (360 °).

DIMENSIONS (1/100)

